

# Краны пробковые проходные сальниковые (код AZ390) Краны пробковые конусные натяжные (код AZ391)

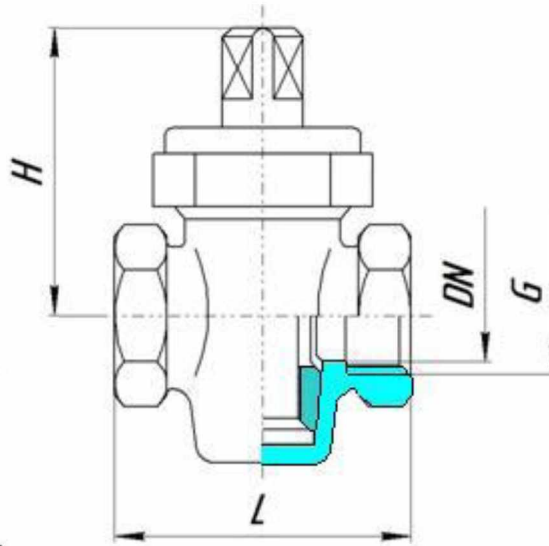

Обозначение	DN	PN кгс/см <sup>2</sup>	L	G	H	Масса, кг, не более
AZ 390-015-0,6 B960 C030 D01	15	6,0	55	G <sup>1</sup> / <sub>2</sub>	74	0,29
AZ 390-020-0,6 B960 C030 D01	20		60	G <sup>3</sup> / <sub>4</sub>		0,33
AZ 390-025-0,6 B960 C030 D01	25		75	G 1	88	0,65
AZ 390-032-0,6 B960 C030 D01	32		85	G 1 <sup>1</sup> / <sub>4</sub>	105	0,92
AZ 390-040-0,6 B960 C030 D01	40		100	G 1 <sup>1</sup> / <sub>2</sub>	120	1,29
AZ 390-050-0,6 B960 C030 D01	50		115	G 2	136	2,22
AZ 390-015-1,0 B960 C030 D01	15	10,0	55	G <sup>1</sup> / <sub>2</sub>	74	0,29
AZ 390-020-1,0 B960 C030 D01	20		60	G <sup>3</sup> / <sub>4</sub>		0,33
AZ 390-025-1,0 B960 C030 D01	25		75	G 1	88	0,65
AZ 390-032-1,0 B960 C030 D01	32		85	G 1 <sup>1</sup> / <sub>4</sub>	105	0,92
AZ 390-040-1,0 B960 C030 D01	40		100	G 1 <sup>1</sup> / <sub>2</sub>	120	1,29
AZ 390-050-1,0 B960 C030 D01	50		115	G 2	136	2,22

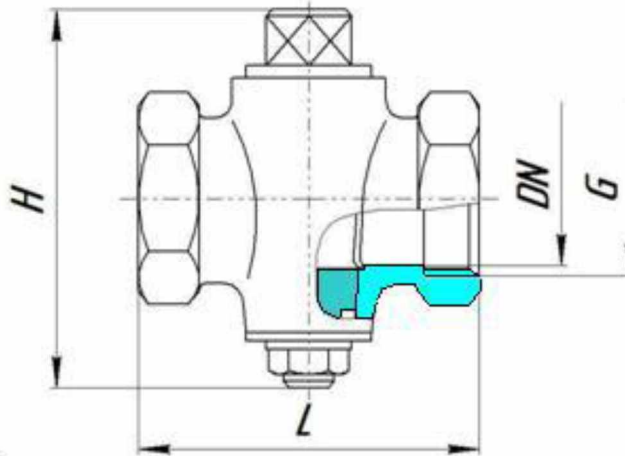

Обозначение	DN	PN кгс/см <sup>2</sup>	L	G	H	Масса, кг, не более
AZ 391-020-0,6 B960 C030 D01	20	6,0	65	G <sup>3</sup> / <sub>4</sub>	76	0,36
AZ 391-025-0,6 B960 C030 D01	25		80	G 1	94	0,63

""3: 4-85/; 2/94""      ""6: 54-99/56/28""      ""573; 77/25/35""      ""564-427/; 3/69""      ""5684-99/; :/57""  
 ""9394-949/354""      ""5634-48/25/7: ""      ""6: 7-48: /26/92""      / / ""8: 85-52: /3: /37""      ""6: 44-85/53/57""  
 ""734; ; /68/26""      ""6: 65-428/23/6: ""      ""374-7; /86/; 5""      ""6: 34-68/83/86""      ""5: 44; ; /63/75""  
 ""5: 74-95/26/82""      ""6: 64; ; 4/45/89""      ""774-42/75/63""      ""6: 68-428/25/38""      ""6: 94-96/24/4: ""  
 ""6944-62/45/86""      ""5: 64-87/26/84""      ""5: 53-64; /2: /34""      /      ""34-52; /68/62""      ""5674-88/43/3: ""  
 ""6: 54-7; /25/74""      ""5: 554-8; /24/26""      ""5: 65-42/68/; 3""      /      ""67-46; /5: /9: ""      ""644-46/45/7; ""  
 ""645-46: /4: /53""      ""83-425/62/; 2""      ""5: 5-449/; 8/95""      ""8: 4-44/53/; 5""      ""569-44; /6: /34""      ""6434; 4/; :/26""  
 ""66-49: /25/6: ""      ""5: 3-426/85/83""      ""5: 34-43/68/62""      ""8: 84-66/75/64""      ""5874-89/35/78""      ""573-424/25/83""  
 ""394-48/63/7: ""      ""6934-99/35/26""      ""6: 84-66/75/64""      ""6: 34-4; /63/76""      ""6: 84-447/94/53""      ""424-6; /24/86""  
 ""695-426/73/95""      ""6964-74/42/; 3""      ""5754-59/8; /26""      ""84-447/94/53""      ""874-42/87/35""      ""74-8; /74/; 5""  
 ""565-5: 6/77/; : ""      ""94-956/; 74/53""      ""634-44/53/38""      ""874-42/87/35""      ""74-8; /74/; 5""

""; ; 8-534/; 8/48/69""

""94-956/; 74/53""

""; ; 4-649/; 4/; 4/8; ""

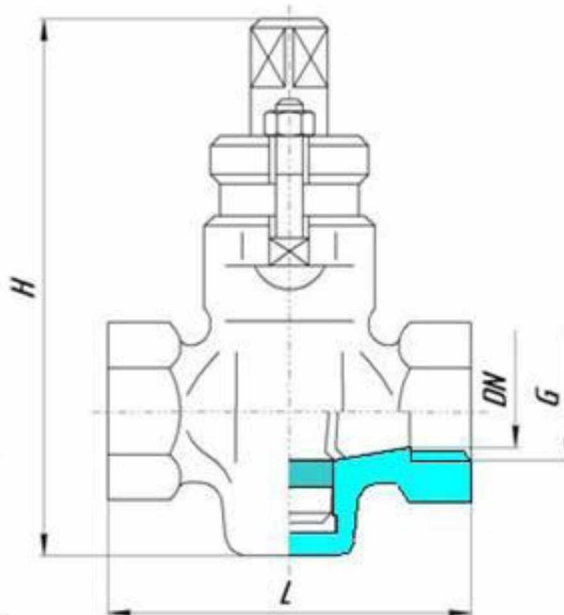

Обозначение	DN	PN кгс/см <sup>2</sup>	L	G	H	Масса, кг, не более
AZ 390-015-1,0 B901 C030 D01	15	10,0	80	G <sup>1/2</sup>	110	0,6
AZ 390-020-1,0 B901 C030 D01	20		90	G <sup>3/4</sup>	132	1,1
AZ 390-025-1,0 B901 C030 D01	25		110	G 1	150	1,8
AZ 390-032-1,0 B901 C030 D01	32		130	G 1 <sup>1/4</sup>	126	2,4
AZ 390-040-1,0 B901 C030 D01	40		150	G 1 <sup>1/2</sup>	230	3,6
AZ 390-050-1,0 B901 C030 D01	50		170	G 2	260	6,5
AZ 390-065-1,0 B901 C030 D01	65		220	G2 <sup>1/2</sup>	305	12,2
AZ 390-080-1,0 B901 C030 D01	80		250	G3	246	17,8

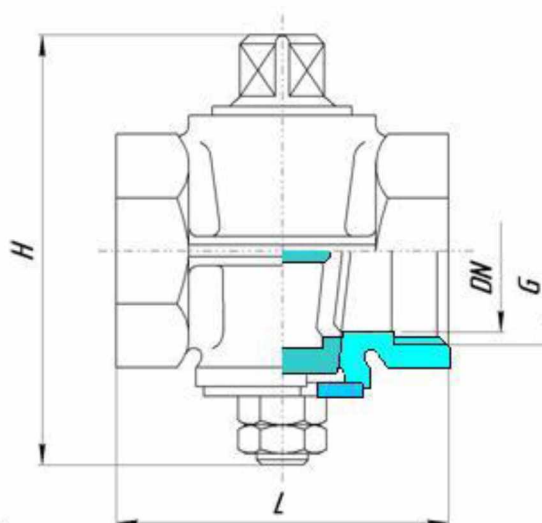

Обозначение	DN	PN кгс/см <sup>2</sup>	L	G	H	Масса, кг, не более
AZ 391-025-1,0 B901 C030 D01	25	10,0	80	G 1	107	0,89
AZ 391-032-1,0 B901 C030 D01	32		95	G 1 <sup>1/4</sup>	118	1,37
AZ 391-040-1,0 B901 C030 D01	40		110	G 1 <sup>1/2</sup>	136	2,02
AZ 391-050-1,0 B901 C030 D01	50		130	G 2	161	3,41
AZ 391-065-1,0 B901 C030 D01	65		160	G2 <sup>1/2</sup>	193	5,71
AZ 391-080-1,0 B901 C030 D01	80		180	G3	227	8,64

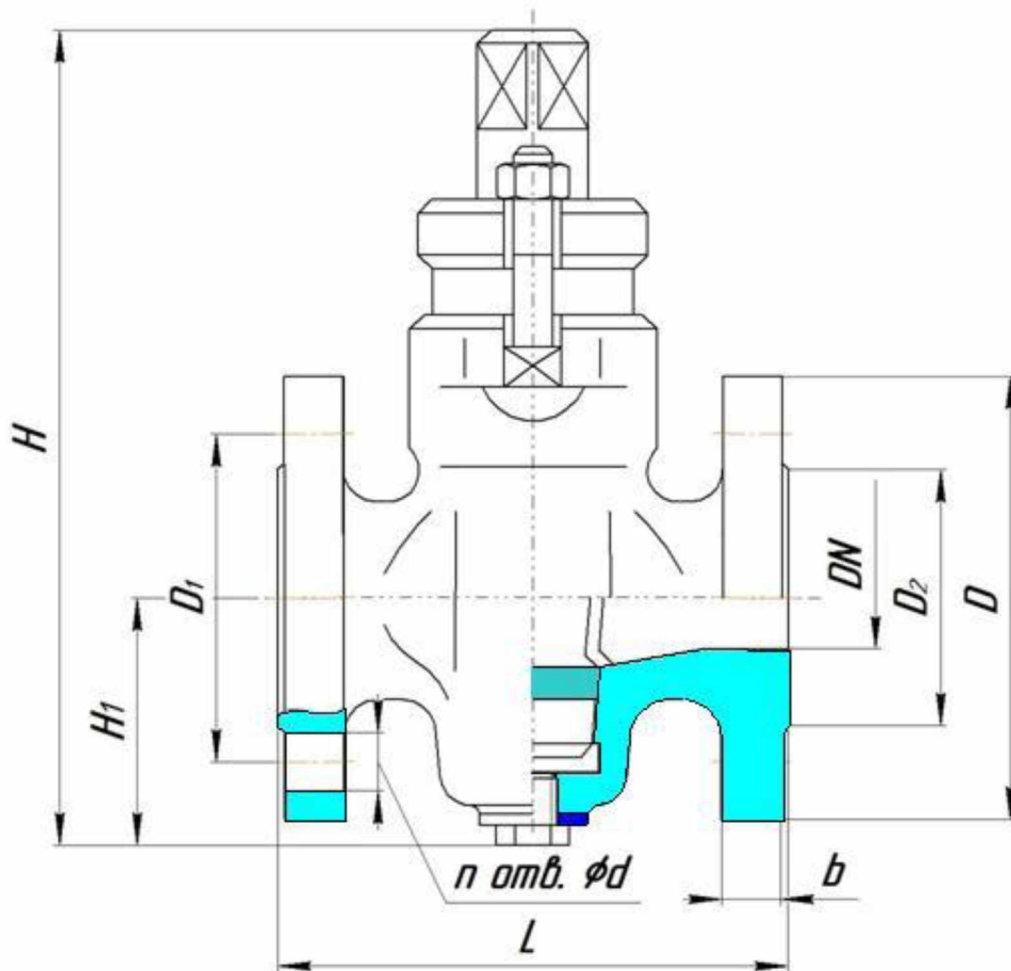

Обозначение	DN	PN кгс/см <sup>2</sup>	L	D	D <sub>1</sub>	D <sub>2</sub>	H	H <sub>1</sub>	b	d	n	Масса, кг, не более
AZ 390-025-1,0 B901 C010 D01	25	10	110	115	85	68	164	44	14	14	4	3,4
AZ 390-040-1,0 B901 C010 D01	40		150	145	110	88	230	90	16	18		7,3
AZ 390-050-1,0 B901 C010 D01	50		170	160	125	102	260	96	17			10,6
AZ 390-065-1,0 B901 C010 D01	65		220	180	145	122	305	110	17			16,8
AZ 390-080-1,0 B901 C010 D01	80		250	195	160	138	345	134	19			22,0
AZ 390-100-1,0 B901 C010 D01	100		300	215	180	158	392	145		19		8

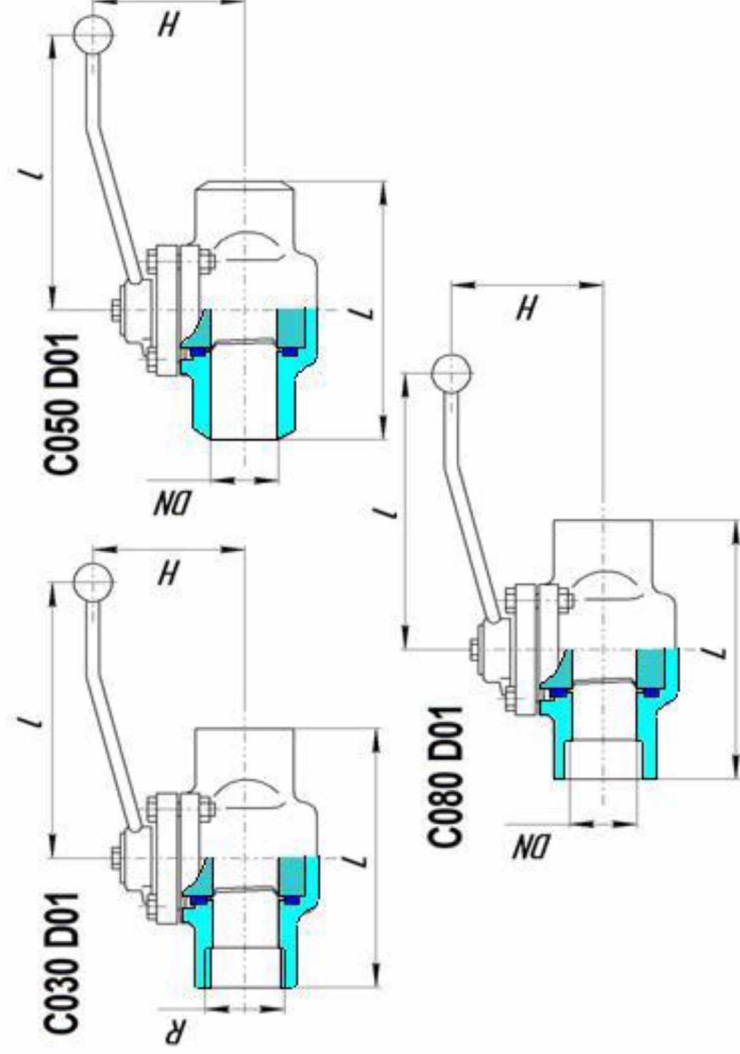

Обозначение	DN	PN* кгс/см <sup>2</sup>	L	H	l	R	Масса, кг, не более		
AZ 390-015-1,0(-1,6;-2,5;-4,0)C030 D01	15	От 10 до 40	85	76	180	R <sup>1/2</sup>	1,1		
AZ 390-015-1,0(-1,6;-2,5;-4,0)C050 D01						—	1,1		
AZ 390-015-1,0(-1,6;-2,5;-4,0)C080 D01						R <sup>3/4</sup>	1,0		
AZ 390-020-1,0(-1,6;-2,5;-4,0)C030 D01	20		От 10 до 40	118	96	260	—	1,0	
AZ 390-020-1,0(-1,6;-2,5;-4,0)C050 D01							—	1,1	
AZ 390-020-1,0(-1,6;-2,5;-4,0)C080 D01							—	1,0	
AZ 390-025-1,0(-1,6;-2,5;-4,0)C030 D01	25			От 10 до 40	140	106	362	R1	2,5
AZ 390-025-1,0(-1,6;-2,5;-4,0)C050 D01								—	2,8
AZ 390-025-1,0(-1,6;-2,5;-4,0)C080 D01								—	2,6
AZ 390-040-1,0(-1,6;-2,5;-4,0)C030 D01	40				От 10 до 40	165	118	435	R <sup>1/2</sup>
AZ 390-040-1,0(-1,6;-2,5;-4,0)C050 D01		—							4,0
AZ 390-040-1,0(-1,6;-2,5;-4,0)C080 D01		—							3,8
AZ 390-050-1,0(-1,6;-2,5;-4,0)C030 D01	50	От 10 до 40				220	132	435	R2
AZ 390-050-1,0(-1,6;-2,5;-4,0)C050 D01			—						6,7
AZ 390-050-1,0(-1,6;-2,5;-4,0)C080 D01			—						6,5
AZ 390-080-1,0(-1,6;-2,5;-4,0)C030 D01	80		От 10 до 40			220	132	435	R3
AZ 390-080-1,0(-1,6;-2,5;-4,0)C050 D01				—					9,5
AZ 390-080-1,0(-1,6;-2,5;-4,0)C080 D01				—					9,5

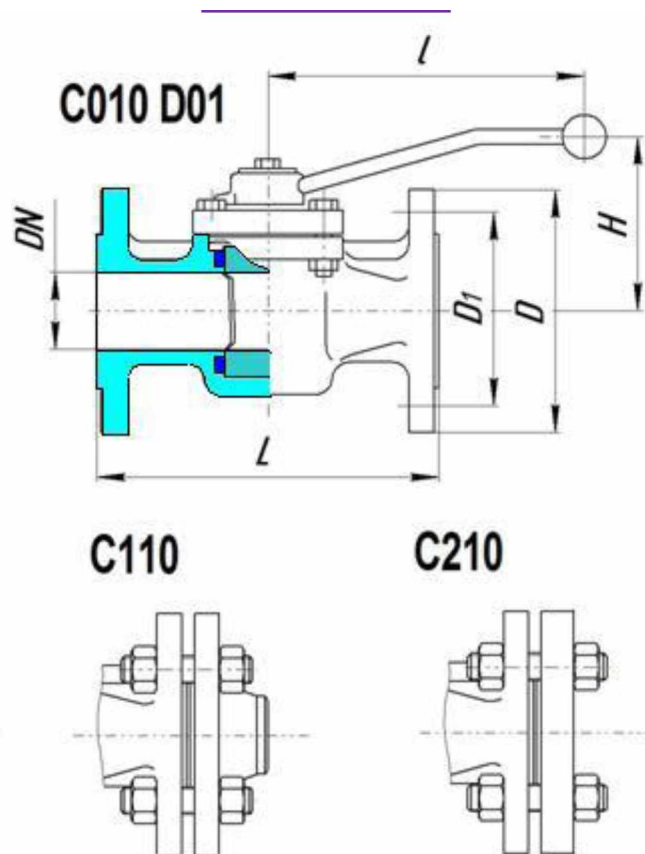

Обозначение	DN	PN* кгс/см <sup>2</sup>	L	H	D	D <sub>1</sub>	l	Масса, кг, не более
AZ 390-015-1,0 C010/110/210 D01	15	10	108,130	76	95	65	180	1,9
AZ 390-015-1,6 C010/110/210 D01		16						2,5
AZ 390-015-2,5 C010/110/210 D01		25	130,140					2,8
AZ 390-015-4,0 C010/110 D01		40						2,3
AZ 390-020-1,0 C010/110/210 D01	20	10	117,130,150	105	75	180	3,4	
AZ 390-020-1,6 C010/110/210 D01		16					3,5	
AZ 390-020-2,5 C010/110 D01		25	150,152				3,5	
AZ 390-020-4,0 C010/110/210 D01		40					3,5	
AZ 390-025-1,0 C010/110/210 D01	25	10	127,140,160	96	115	85	260	5,0
AZ 390-025-1,6 C010/110/210 D01		16						6,6
AZ 390-025-2,5 C010/110/210 D01		25	160,165					4,5
AZ 390-025-4,0 C010/110 D01		40						6,5
AZ 390-032-1,0 C010/110/210 D01	32	10	140,165,180	106	145	110	362	8,3
AZ 390-032-1,6 C010/110/210 D01		16						5,6
AZ 390-032-2,5 C010/110/210 D01		25	178,180					8,8
AZ 390-032-4,0 C010/110 D01		40						11,0
AZ 390-040-1,0 C010/110/210 D01	40	10	165,200	118	160	125	435	9,6
AZ 390-040-1,6 C010/110/210 D01		16						12,4
AZ 390-040-2,5 C010/110/210 D01		25	190,200					13,8
AZ 390-040-4,0 C010/110 D01		40						10,5
AZ 390-050-1,0 C010/110/210 D01	50	10	178,203,230	112	180	145	435	13,4
AZ 390-050-1,6 C010/110/210 D01		16						14,9
AZ 390-050-2,5 C010/110/210 D01		25	216,230					14,0
AZ 390-050-4,0 C010/110D01		40						21,4
AZ 390-065-1,0 C010/110/210 D01	65	10	190,222,290	132	195	160	435	10,5
AZ 390-065-1,6 C010/110/210 D01		16						13,4
AZ 390-065-2,5 C010/110/210 D01		25	241,290					14,9
AZ 390-065-4,0 C010/110 D01		40						14,0
AZ 390-080-1,0 C010/110/210 D01	80	10	203,241,310	132	195	160	435	14,0
AZ 390-080-1,6 C010/110/210 D01		16						21,4
AZ 390-080-2,5 C010/110/210 D01		25	283,310					

AZ 390-080-4,0 C010/110 D01		40						26,3
AZ 390-100-1,0 C010/110/210 D01	100	10	229,305,350	151	215	180	600	27,2
AZ 390-100-1,6 C010/110/210 D01		16						38,4
AZ 390-100-2,5 C010/110/210 D01		25	305,350		230	190		50,8
AZ 390-100-4,0 C010/110 D01		40						

**C010 D10**

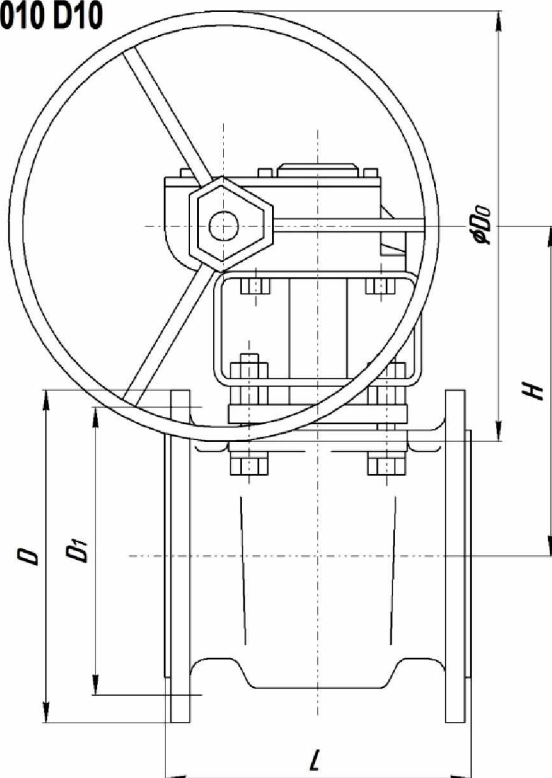

**C110**

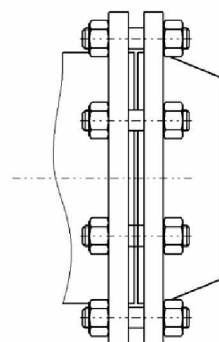

**C210**

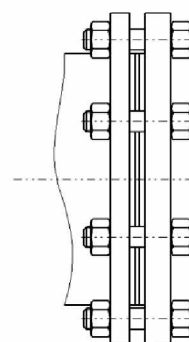

Обозначение	DN	PN* кгс/см <sup>2</sup>	L	H	D	D <sub>1</sub>	D <sub>0</sub>	Масса, кг, не более	
AZ 390-080-1,0 C010/110/210 D10	80	10	203,241,310	204	195	160	200	27,8	
AZ 390-080-1,6 C010/110/210 D10		16						34,6	
AZ 390-080-2,5 C010/110/210 D10		25	283,310					40,4	
AZ 390-080-4,0 C010/110 D10		40						44,3	
AZ 390-100-1,0 C010/110/210 D10	100	10	229,305,350	235	215	180	600	45,5	
AZ 390-100-1,6 C010/110/210 D10		16						57,7	
AZ 390-100-2,5 C010/110/210 D10		25	305,350		230	190		300	67,7
AZ 390-100-4,0 C010/110 D10		40							77,2
AZ 390-125-1,0 C010/110/210 D10	125	10	254,356,400	308	245	210	300	55,0	
AZ 390-125-1,6 C010/110/210 D10		16						67,3	
AZ 390-125-2,5 C010/110/210 D10		25	381,400		270	220		300	44,8
AZ 390-125-4,0 C010/110 D10		40							55,2
AZ 390-150-1,0 C010/110/210 D10	150	10	267,394,480	345	280	240	300	67,7	
AZ 390-150-1,6 C010/110/210 D10		16						77,2	
AZ 390-150-2,5 C010/110/210 D10		25	403,419,480		300	250		300	89,0
AZ 390-150-4,0 C010/110 D10		40							104,5
AZ 390-200-1,0 C010/110/210 D10	200	10	292,457,600	345	335	295	300	133	
AZ 390-200-1,6 C010/110/210 D10		16						146	
AZ 390-200-2,5 C010/110/210 D10		25	457,600		360	310		300	178
AZ 390-200-4,0 C010/110 D10		40							169
AZ 390-250-1,0 C010/110/210 D10	250	10	330,533,750	360	405	355	457	146	
AZ 390-250-1,6 C010/110/210 D10		16						178	
AZ 390-250-2,5 C010/110/210 D10		25	502,750		425	370		457	178
AZ 390-250-4,0 C010/110 D10		40							178
AZ 390-300-1,0 C010/110/210 D10	300	10	356,610,850	478	440	400		169	

AZ 390-300-1,6 C010/110/210 D10		16		460	410		186
AZ 390-300-2,5 C010/110/210 D10		25		485	430		
AZ 390-300-4,0 C010/110 D10		40	356,850	510	450		225
AZ 390-350-1,0 C010/110/210 D10	350	10	381,686,980	500	460	517	762
AZ 390-350-1,6 C010/110/210 D10		16		520	470		
AZ 390-350-2,5 C010/110 D10		25		550	490		
AZ 390-350-4,0 C010/110/210 D10		40	762,980	570	510		435
AZ 390-400-1,0 C010/110/210 D10	400	10	406,762,1100	565	515		378
AZ 390-400-1,6 C010/110/210 D10		16		580	525	400	
AZ 390-400-2,5 C010/110/210 D10		25		610	550		
AZ 390-400-4,0 C010/110 D10		40		838,1100	655	585	455

## Кран пробковый конусный трёхходовой (код AZ392)

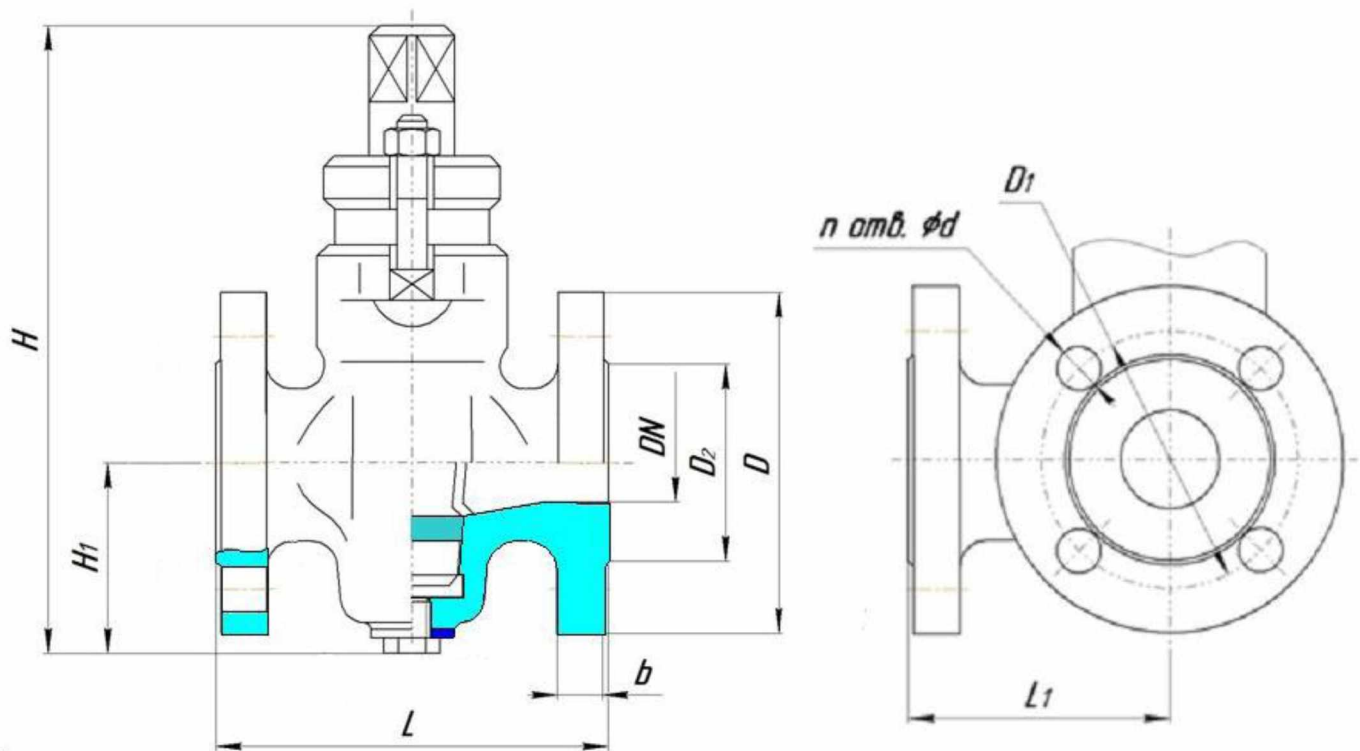

Обозначение	DN	PN кгс/см <sup>2</sup>	L	D	D <sub>1</sub>	D <sub>2</sub>	H	H <sub>1</sub>	b	d	n	Масса, кг, не более
AZ 392-025-0,6 B901 C010 D01	25	6,0	145	100	75	60	185	50	12	11	4	4,4
AZ 392-040-0,6 B901 C010 D01	40		180	130	100	80	276	95	13	14		10,4
AZ 392-050-0,6 B901 C010 D01	50		200	140	110	90	318	110				
AZ 392-065-0,6 B901 C010 D01	65		230	160	130	110	385	132	15	18		16,0
AZ 392-080-0,6 B901 C010 D01	80		260	185	150	128	406	145				
AZ 392-100-0,6 B901 C010 D01	100		350	205	170	148	440	165				47,2

\*\*\*: 3: 4-85/; 2/94\*\*\*\*  
 \*\*\*\*9394-949/354\*\*\*\*  
 \*\*\*: 734-г; /68/26\*\*\*\*  
 \*\*\*\*5: 74-95/26/82\*\*\*\*  
 \*\*\*\*6944-62/45/86\*\*\*\*  
 \*\*\*\*6: 54-7; /25/74\*\*\*\*  
 \*\*\*\*645-46; /4: /53\*\*\*\*  
 \*\*\*: 66-49; /25/6: \*\*\*\*  
 \*\*\*\*: 394-48/63/7: \*\*\*\*  
 \*\*\*\*695-426/73/95\*\*\*\*  
 \*\*\*\*565-5; 6/77: ; \*\*

\*\*\*\*6: 54-99/56/28\*\*\*\*  
 \*\*\*\*5634-48/25/7: \*\*\*\*  
 \*\*\*\*: 65-428/23/6: \*\*\*\*  
 \*\*\*\*6234-94/25/: 3\*\*\*\*  
 \*\*\*\*6: 64-г; 4/45/89\*\*\*\*  
 \*\*\*\*5: 64-87/26/84\*\*\*\*  
 \*\*\*\*: 554-8; /24/26\*\*\*\*  
 \*\*\*\*: 83-425/62/; 2\*\*\*\*  
 \*\*\*\*5: 3-426/85/83\*\*\*\*  
 \*\*\*\*6934-99/35/26\*\*\*\*  
 \*\*\*\*6964-74/42/: 3"

\*\*\*; 8-534/; 8/48/69"

\*\*\*\*573; -77/25/35\*\*\*\*  
 \*\*\*\*5634-48/25/7: \*\*\*\*  
 \*\*\*\*: 7-48; /26/92\*\*\*\*  
 \*\*\*\*: 374-7; /86/: 5\*\*\*\*  
 \*\*\*\*6234-94/25/: 3\*\*\*\*  
 \*\*\*\*: 53-64; /2: /34\*\*\*\*  
 \*\*\*\*: 53-64; /2: /34\*\*\*\*  
 \*\*\*\*: 65-42/68/: 3\*\*\*\*  
 \*\*\*\*5: 5-449/: 8/95\*\*\*\*  
 \*\*\*\*: 34-43/68/62\*\*\*\*  
 \*\*\*\*6: 84-66/75/64\*\*\*\*  
 \*\*\*\*5754-59/8: /26\*\*\*\*  
 \*\*\*\*: 634-44/53/38"

\*\*\*\*994-956/; 74/53"

\*\*\*\*564-427/: 3/69\*\*\*\*  
 / / \*\*\*\*: 85-52/: 3/: 37\*\*\*\*  
 \*\*\*\*6: 34-68/83/86\*\*\*\*  
 \*\*\*\*: 68-428/25/38\*\*\*\*  
 / \*\*\*\*: 34-52; /68/62\*\*\*\*  
 \*\*\*\*: 67-46; /5: /9: \*\*\*\*  
 \*\*\*\*5: 5-449/: 8/95\*\*\*\*  
 \*\*\*\*5874-89/35/78\*\*\*\*  
 \*\*\*\*6: 34-4; /63/76\*\*\*\*  
 \*\*\*\*: 84-447/94/53\*\*\*\*  
 \*\*\*\*: 874-42/87/35\*\*\*\*

\*\*\*; 4-649/; 4/; 4/8; "

\*\*\*\*5684-99:; /57\*\*\*\*  
 \*\*\*\*6: 44-85/53/57\*\*\*\*  
 \*\*\*\*5: 44-г; /63/75\*\*\*\*  
 \*\*\*\*6: 94-96/24/4; \*\*\*\*  
 \*\*\*\*5674-88/43/3: \*\*\*\*  
 \*\*\*\*: 644-46/45/7; \*\*\*\*  
 \*\*\*\*569-44; /6: /34\*\*\*\*  
 \*\*\*\*6434-г; 4/: /26\*\*\*\*  
 \*\*\*\*573-424/25/83\*\*\*\*  
 \*\*\*\*: 424-6; /24/86\*\*\*\*  
 \*\*\*\*6: 74-8; /74/: 5\*\*\*\*